

PRELIMINARY ISSUE - NOT FOR MANUFACTURE

APPROVED FOR	SIGNED	DATE
QUOTATION		
MATL ORDER		
MANUFACTURE		
REWORK		

REV.	DESCRIPTION	DATE	APPROVED
REVISION TABLE			

#	NOTES
1	
2	
3	
4	
5	
6	MATERIAL
7	QTY
8	TOT QTY
9	FINISH
10	VENDOR
11	WELDING

PROJECT	CLIENT
<p>Lanark VICTORIA - HEAD OFFICE BATHROOMWARE SPAS & HOT TUBS Ph: (03) 9768 2077 Fax: (03) 9768 3036 Email: vcs@lanark.com.au</p> <p>Design by View7</p>	<p>3RD ANGLE DEBUR AND BREAK SHARP U.O.S. GENERAL TOLERANCE +/- 0.5mm DATE: 29/10/2008 SIGNATURE: [Blank] DATE: [Blank] U.O.S. CHECKED: [Blank] DATE: [Blank] U.O.S. DESIGNED BY: [Blank] DATE: [Blank] U.O.S.</p>

TITLE	DWG NO.	SHEET SCALE	SHEET	TOTAL SHEETS
JULIET 1500	V774-22	1:3	1	2

ALL DIMENSIONS GIVEN UNLESS OTHERWISE SPECIFIED. THE SOLE PROPERTY OF LANARK. AND MAY NOT BE COPIED OR REPRODUCED WITHOUT PERMISSION.

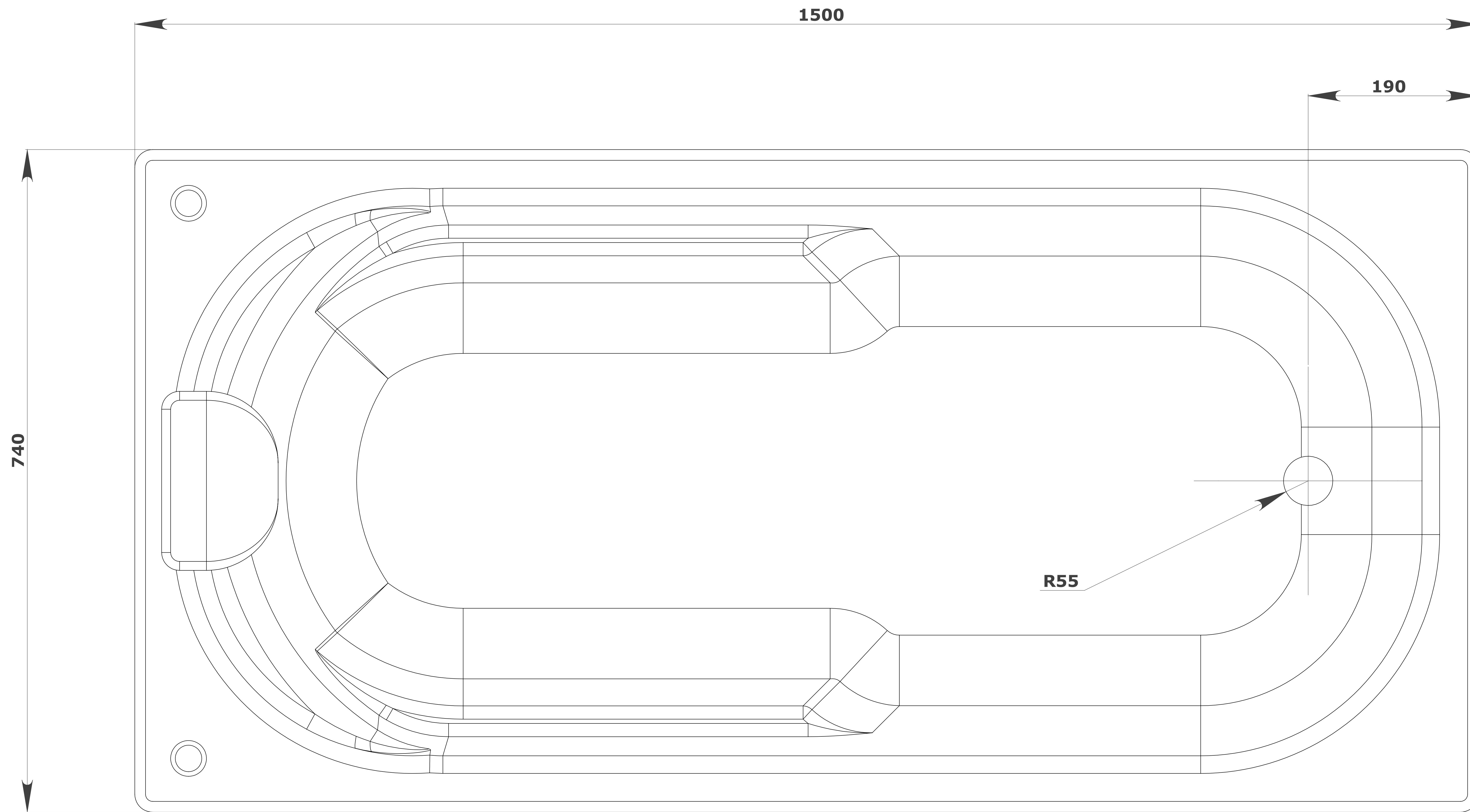

JULIET 1500